



RD155

**mitsubishi 9.5",
33 SPLINE, IRS**

**AIR OPERATED
LOCKING DIFFERENTIAL
INSTALLATION GUIDE**

No liability is assumed for damages resulting in the use of the information contained herein.
ARB Air Locker Locking Differentials and Air Locker are trademarks of ARB Corporation Limited.
Other product names used herein are for identification purposes only and may be trademarks of their respective owners.



ARB 4x4 ACCESSORIES

Corporate Head Office

42-44 Garden St
Kilsyth, Victoria
AUSTRALIA
3137

Tel: +61 (3) 9761 6622
Fax: +61 (3) 9761 6807

Australian enquiries
North and South American enquiries
Other international enquiries

sales@arb.com.au
sales@arb.com.au
exports@arb.com.au

www.arb.com.au

Table of Contents:

1	Introduction	3
1.1	Pre-Installation Preparation	3
1.2	Tool-Kit Recommendations	4
2	Removing the Existing Differential	5
2.1	Vehicle Support	5
2.2	Differential Fluid Drain	5
2.3	Removing the Axles and Differential	5
2.4	Marking the Bearing Caps	6
2.5	Checking the Current Backlash Amount	6
2.6	Spreading the Differential Housing	8
3	Bench Measurement	9
3.1	Approximate Backlash Shimming	9
3.2	Calculation & Selection of Shims	11
4	Installing the Air Locker	12
4.1	Installing the Carrier Bearings	12
4.2	Mounting the Ring Gear	12
4.3	Assembling the Seal Housing	13
4.4	Calculation & Selection of Pre-Load Shims	14
4.5	Drilling and Tapping the Bulkhead Port	16
4.6	Final Air Locker Assembly	17
4.7	Final Backlash Checking	17
4.8	Profiling the Seal Housing Tube	18
4.9	Setting up the Bulkhead Fitting	20
4.10	Bench Testing the Air Locker	22
4.11	Reinstalling the Differential and Axles	23
5	Installing the Air System	24
5.1	Mounting the Solenoid	24
5.2	Running & Securing the Air Line	26
5.3	Connection to the Bulkhead Fitting	27
6	Mounting & Connecting the Electrical System	28
6.1	Mounting the Actuator Switch(es)	28
6.2	Wiring the Actuator System	29
7	Testing & Final Assembly	32
7.1	Leak Testing	32
7.2	Testing the Air Locker Actuation	32
7.3	Filling the Differential	33
7.4	Post-Installation Check List	34
8	Parts List	35
8.1	Exploded Assembly Diagram	35
8.2	Itemized Parts List	36



1 Introduction

IMPORTANT :

BEFORE ATTEMPTING TO DISMANTLE YOUR VEHICLE FOR THIS INSTALLATION, PLEASE READ THIS INSTALLATION GUIDE IN ITS ENTIRETY, AS WELL AS ALL APPLICABLE SECTIONS OF YOUR VEHICLE MANUFACTURER'S SERVICE MANUAL.

1.1 Pre-Installation Preparation

This booklet is to be used in conjunction with your vehicle manufacturer's service manual. ARB endeavors to account for every possible variation in vehicle model when publishing its installation guides, and guides are updated regularly as new model information becomes available, however, the rapid and globally varied release of some vehicles makes it difficult to insure that your vehicle model has been accurately accounted for. In the case of any technical discrepancies between this guide and your service manual, we strongly advise that you adhere to the specifications and techniques as documented in your service manual.

Although your *ARB Air Locker* comes complete with all the step by step instructions you will need to supplement your vehicle manufacturer's service manual and install your new differential, ARB recommends that you have your *Air Locker* installed by a trained professional. Many ARB distributors around the world have been fully instructed in *Air Locker* installations by ARB, and have gained a wealth of experience and skill from years of performing similar installations.

Once you begin this installation your vehicle will be immobile until all steps of the installation are complete. Make sure your *Air Locker* kit is the correct model for your vehicle and that it contains all of the parts listed on back cover of this booklet. Also be sure you have appropriately equipped yourself with all the necessary tools, parts, and materials to complete this installation (see section 1.2 *Tool-Kit Recommendations*), and that you have allowed for an appropriate amount of vehicle down time.

HINT :

Place a ✓ mark inside each of the symbols as you complete each step. It is very important NOT to miss any of the steps!



1 Introduction

1.2 Tool-Kit Recommendations

Below is a list of tools and supplies you may need to complete this installation. Requirements for your vehicle may vary. Please consult your vehicle service manual for additional recommendations.

1.2.1 Tools

- Standard automotive sizes (metric and/or imperial) of sockets, wrenches, Allen keys, and drills.
- A dial indicator or other suitable measuring tool for checking ring & pinion backlash.
- A standard automotive feeler gauge.
- Automotive brake tubing cutters to cut the copper tubing.
- A razor knife to cut the nylon tubing.
- A differential housing spreader, to facilitate removal of the carrier.
- A torque wrench. (See vehicle service manual for required torque range.)
- A lubricant drain reservoir.
- Suitable measuring tools to measure a differential for pre-load and/or backlash shimming. (See Section 3 *Bench Measurement*)
- A 11.2mm [7/16"] drill and ¼" NPT tap for bulkhead fitting installation.
- An automotive bearing puller (2 jawed is recommended) or a differential carrier bearing puller.
- A bearing press or arbor press.

1.2.2 Supplies

- Thread lubricant/sealant compound for pressure fittings (e.g., LOCTITE #567 Teflon paste)
- Thread locking compound (e.g., LOCTITE #272)
- Either a replacement gasket, or gasket sealant.
- A sufficient volume of differential oil to completely refill your housing. (see the *ARB Air Locker Operating and Service Manual* for recommended lubricants)
- A soap and water mixture to test for air leaks.
- A selection of differential bearing shims to set-up pre-load and backlash. (See section 3 *Bench Measurement*)



2 Removing the Existing Differential

2.1 Vehicle Support

- Safely secure the vehicle on a hoist. We recommend supporting the vehicle on a chassis hoist to keep the differential area at a convenient working height and to leave the wheels and axles free to be rotated and removed.
- Once supported off the ground, release the parking brake and leave the vehicle in neutral. Chock the wheels if necessary.

2.2 Differential Fluid Drain

- Position a fluid drain reservoir under the differential.
- Remove fluid drain plug to empty all differential oil.

HINT : This is a good time to check for metal particles in your oil which may indicate a worn bearing or differential component.

2.3 Removing the Axles and Differential

- Remove the axles as per your vehicle's service manual.
- Disconnect the drive shaft from the flange of the differential.
- Remove the differential from the vehicle. (Refer to your vehicle's service manual)

NOTE : The differential housing is heavy and quite difficult to handle when covered in oil. Do not drop it!

NOTE : Check the axle shaft oil seals for signs of wear or damage, and replace if necessary.

2 Removing the Existing Differential

2.4 Marking the Bearing Caps

- Remove the inspection cover.
- Using a pointed center punch, gently mark the differential housing and the bearing caps in a way that will enable you to correctly position the cap during reassembly. (Fig.1.)



Figure 1.

2.5 Checking the Current Backlash Amount

IMPORTANT:

This step is a precautionary measure recommended by ARB due to the fact that some after market ring and pinion sets have been manufactured to run with different backlash settings than those specified by your vehicle manufacturer. Although ARB must recommend you set backlash according to your service manual guidelines, we also advise that you compare the backlash measurements taken here to the recommended backlash settings in your vehicle service manual. Measurements found to be outside of your service manual recommendations may indicate the need to deviate from those settings in order to achieve quiet running with a good contact mark.

Refer to your vehicle service manual or your local authorized ARB installer for more information.

2 Removing the Existing Differential

- Set a depth indicator on one of the ring gear teeth as in Figure 2.

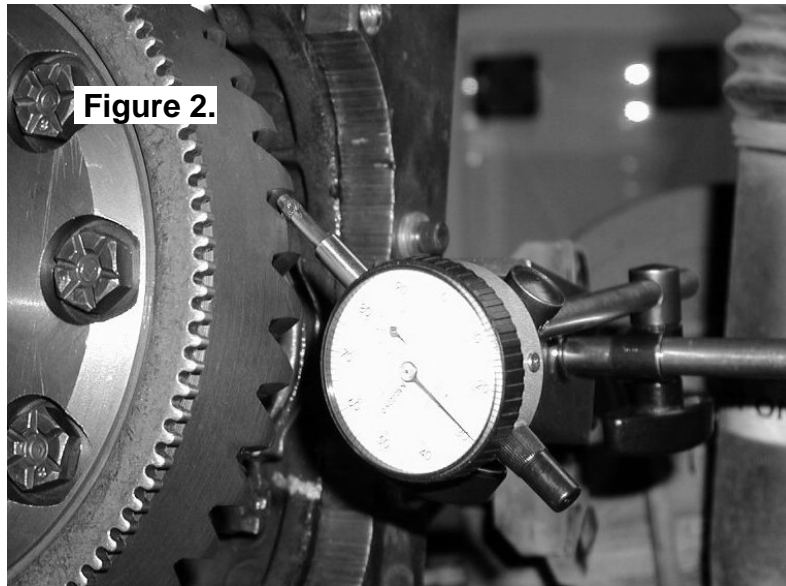

- While supporting the pinion gear by holding the drive shaft, rotate the differential in both directions while observing the maximum variation in depth from the indicator (i.e., the highest value minus the lowest value). This value is referred to as the ring and pinion backlash.
- Rotate the differential center 90° and measure again for accuracy.
- Record the average of all measurements.

2 Removing the Existing Differential

2.6 Spreading the Differential Housing

IMPORTANT:

Spreading the differential housing with a differential case spreader is a step which is critical to set up bearing pre-load when a differential is installed. Improper pre-load will result in undue bearing wear, increased stresses in the differential center, increased running noise, and ultimately, ring and pinion gear damage.

- Unbolt and remove the bearing caps.
- Setup the differential spreader and a dial indicator and carefully spread the differential housing (Fig.3.) just enough to remove the differential carrier (Refer to your vehicle's service manual).

NOTE : Never spread the housing more than 0.5mm [0.020"].

- Once the housing has been adequately spread, the differential may be removed by pulling forward on the differential center.
- Remove spreader tension.

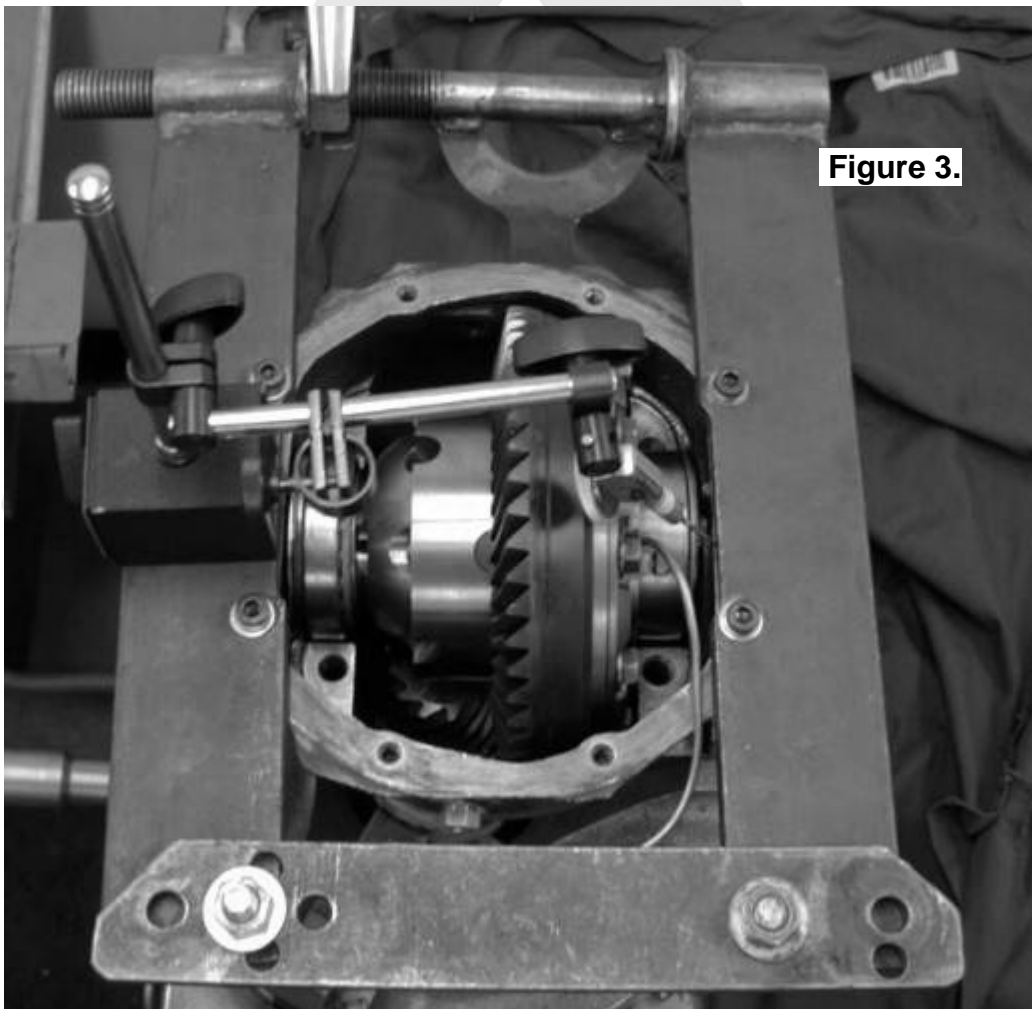

Figure 3.

3 Bench Measurement

3.1 Approximate Backlash Shimming

In order to reproduce a similar pre-load and ring and pinion backlash in your *Air Locker* to that of your original differential, measurements need to be taken so that a shim thickness can be calculated.

- Secure the original differential to a work bench.
- Remove the bolts that hold the ring gear in place.
- Using a plastic or copper hammer, tap in a circle around the ring gear to separate it from the differential carrier.
- Remove the original bearings and shims from the differential center using a bearing puller.

NOTE : Keep the bearings and shims separated so that they can be identified as to which end of the differential they came from.

- Examine the bearing cups and cones from Figure 4. for damage or wear and, if necessary, discard them and replace with the same size and type of bearings.

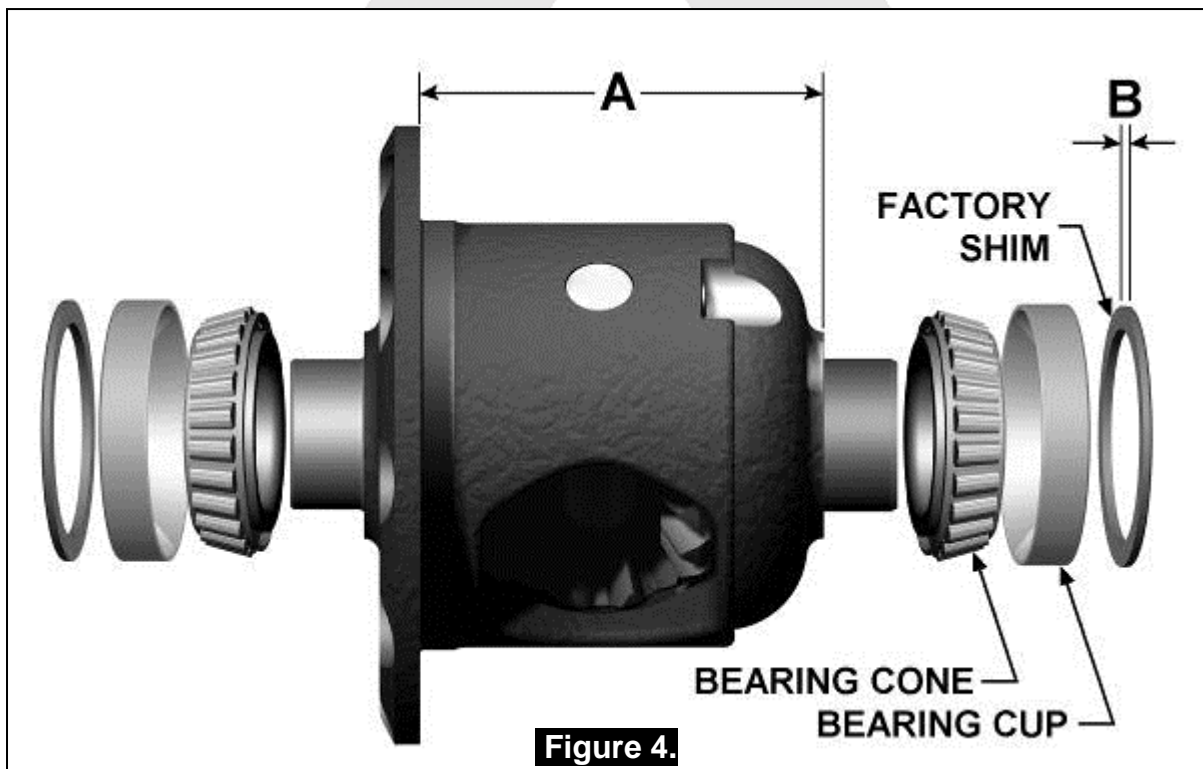

3 Bench Measurement

- Using a caliper or similarly accurate measurement method (i.e., able to take accurate measurements within 0.04mm [0.0015"]), measure the distance from the shoulder of the bearing journal to the ring gear mounting face (shown as 'A' in Fig.4.) and record this measurement as 'A'.
- Measure the thickness of the factory shim removed from the end of the differential carrier (shown as 'B' in Fig.4.) and record this measurement as 'B'.

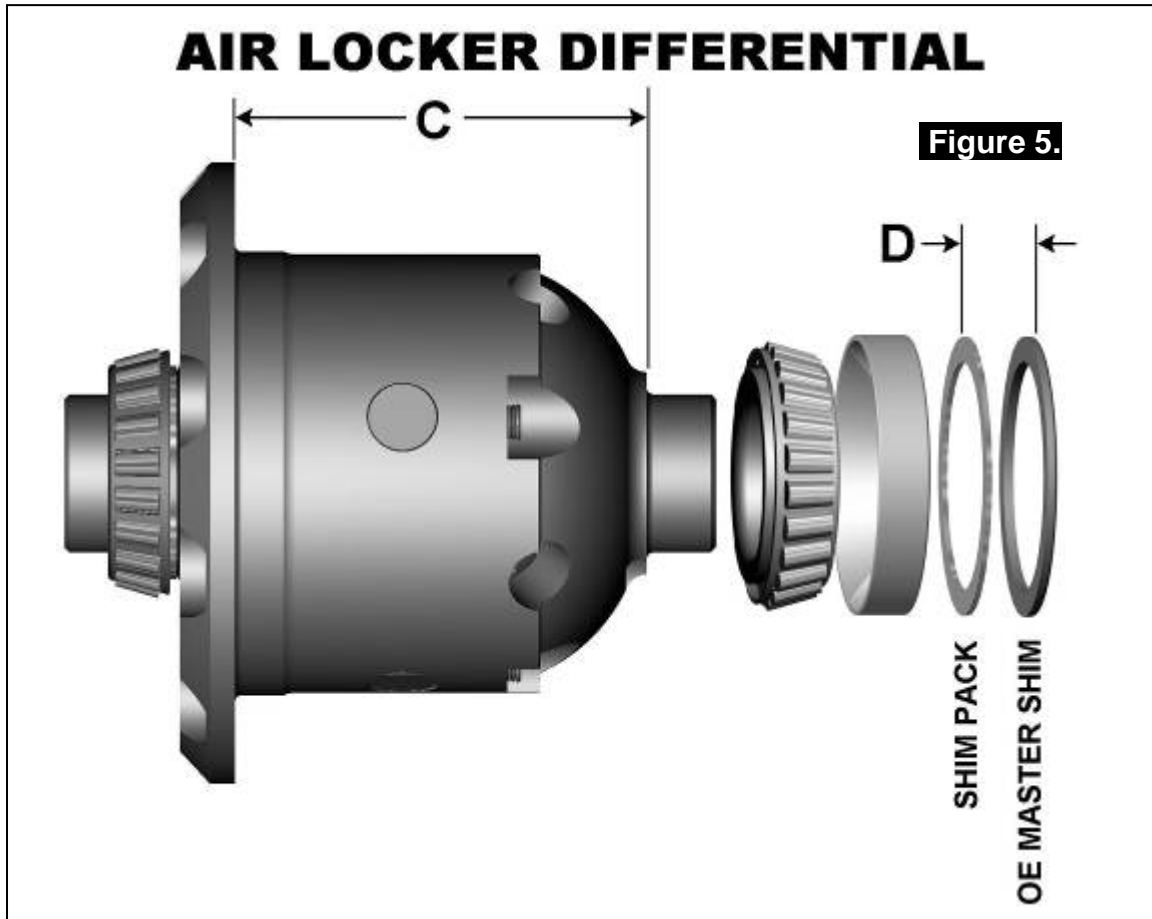

- Measure the distance from the *Air Locker* bearing shoulder to the ring gear mounting face (shown as 'C' in Fig.5.) and record this measurement as 'C'.

3 Bench Measurement

3.2 Calculation & Selection of Shims

Ideally, the measurement you recorded as 'C' from the *Air Locker* differential will closely match 'A' on the existing differential (within 0.1mm [0.004"]) and then the factory shim can be reused, however, quite often these measurements will vary slightly between one factory differential and the next.

If this is the case you must create a new shim pack thickness by using the measurements you recorded earlier to find a desired measurement for 'D' in Figure 5.

Use the following calculation:

$$A + B - C = D \text{ (Replacement Shim Pack)}$$

HINT : If your calculations are correct then the following equation will also be true:

$$A + B - C - D = \text{ZERO}$$

Create a shim pack to match the thickness calculated as 'D'.

To achieve the desired shim thickness you can:

- Machine down the factory shim thickness.
- Add shims between the factory shim and the bearing cup.

HINT : A selection of shims of this size have been supplied with your *Air Locker* kit.

- Purchase new factory shims at the desired thickness.
- Use a universal shim kit available from most drive train specialists.

NOTE : NEVER machine the *Air Locker*.

4 Installing the Air Locker

4.1 Installing the Carrier Bearings

- With the *Air Locker* well supported in an arbor press, apply a thin film of high pressure grease to both bearing journals.
- Press one of the tapered roller bearing cones onto one of the bearing journals of the *Air Locker* until the bearing seats firmly against the bearing journal shoulder.
- Invert the *Air Locker* and press the second bearing cone onto the opposite bearing journal until the bearing seats firmly against the bearing journal shoulder.

NOTE : Never re-use any bearings which are damaged or worn.

4.2 Mounting the Ring Gear

- Apply a thin film of high-pressure grease to the ring gear shoulder of the *Air Locker* to prevent seizing.
- Thoroughly clean any thread locking compound or other foreign matter from the holes of the ring gear, the threads of the ring gear bolts, and the mating surfaces of the ring gear and the *Air Locker* flange.

NOTE : Rubbing the ring gear mounting face with a flat oil stone before installation will remove any high spots around the threads.

- Heat the ring gear to between 80 and 100°C (175 - 212°F) in an oven or in hot water to slightly expand the gear and facilitate assembly.

NOTE : **NEVER HEAT GEARS WITH A FLAME!** This could damage the hardened surface of the gear and result in premature wear or failure.

- Dry the ring gear with compressed air (if wet), paying particular attention to the threaded holes.
- Install the ring gear onto the *Air Locker* by aligning the holes in the flange with the tapped holes in the ring gear, then gently tapping it around in a circle with a plastic or copper hammer.

4 Installing the Air Locker

NOTE : Avoid using the bolts to pull down the ring gear as this puts excess strain on the bolts and the differential flange.

- Apply a thread locking compound to the thread of each ring gear bolt before inserting it.

NOTE : Do not apply threading compound directly into the threaded hole as this could prevent the bolt from reaching its full depth.

- Tighten the ring gear bolts in a star pattern with a torque wrench according to your vehicle manufacturer's specified torque.

4.3 Assembling the Seal Housing

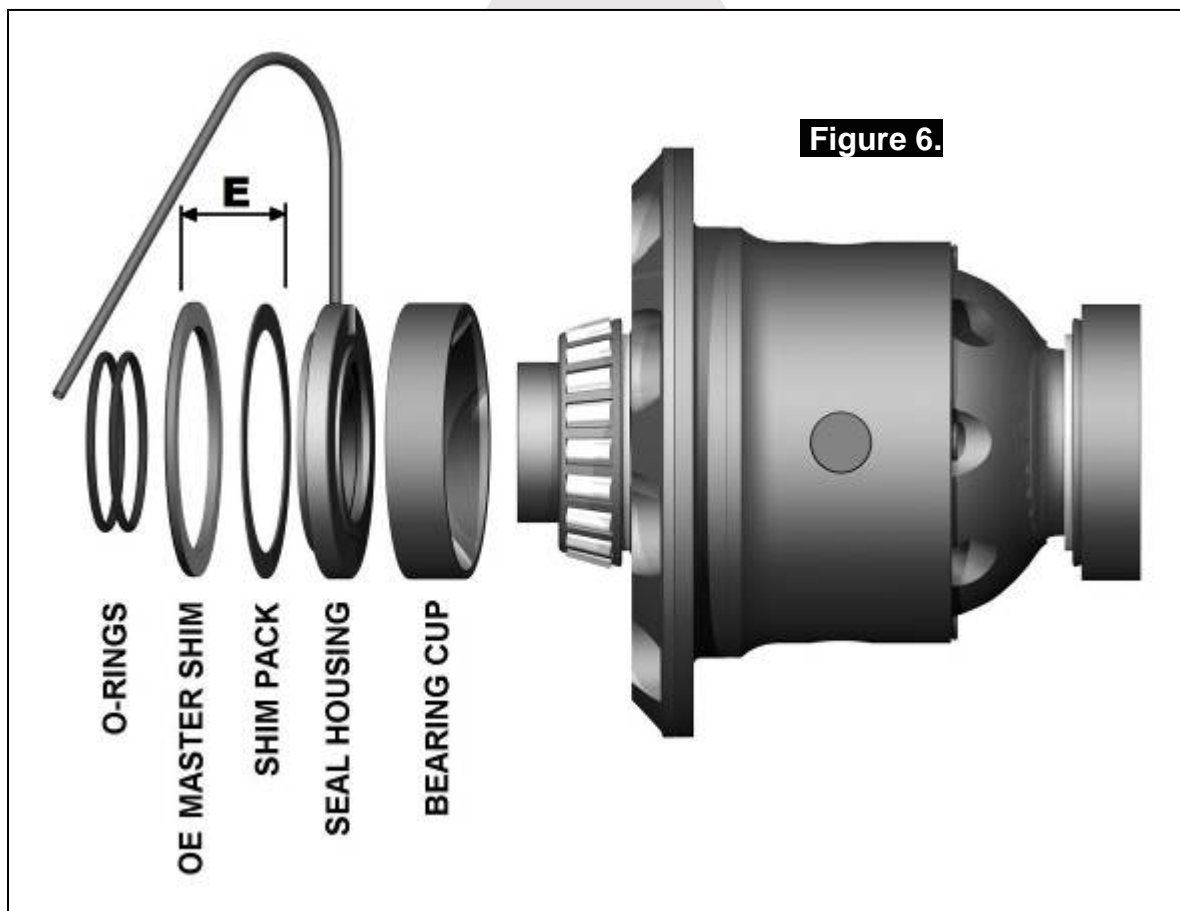

- Make sure the grooves and airway of the seal housing are clean and free from any contaminants (e.g. water, dirt, metal filings, etc.).
- Inspect the seal housing O-rings (supplied) for dirt, damage or other conditions which might cause leaks.

4 Installing the Air Locker

- Generously lubricate the O-rings with oil prior to assembly, then insert them into the grooves of the seal housing.

NOTE : When assembling the O-rings, be careful not to leave them twisted when seated in the grooves as this could cause excessive wear and leakage.

- Lubricate the seal housing running surface on the *Air Locker* carrier with oil. Assemble the bearing cup onto the left-hand side of the *Air Locker*.
- Carefully install the seal housing by sliding it all of the way onto the bearing journal with a gentle twisting motion. This will allow the O-rings to engage gently.

4.4 Calculation & Selection of Pre-Load Shims

In order to pre-load the tapered roller bearings in your *Air Locker*, measurements need to be taken so that a value can be calculated for the shim thickness 'E' in Figure 6.

- Hold the bearing cup and shim pack 'D' (Fig.5.) in place, and insert the *Air Locker* into the housing. Ensure that the seal housing tube is positioned in line with the oil groove in the housing (Fig. 7.).
- Push the *Air Locker* hard across against the bearing and shim pack 'D', and measure the gap between the end of the seal housing and the bearing seat of the differential housing with a feeler gauge.

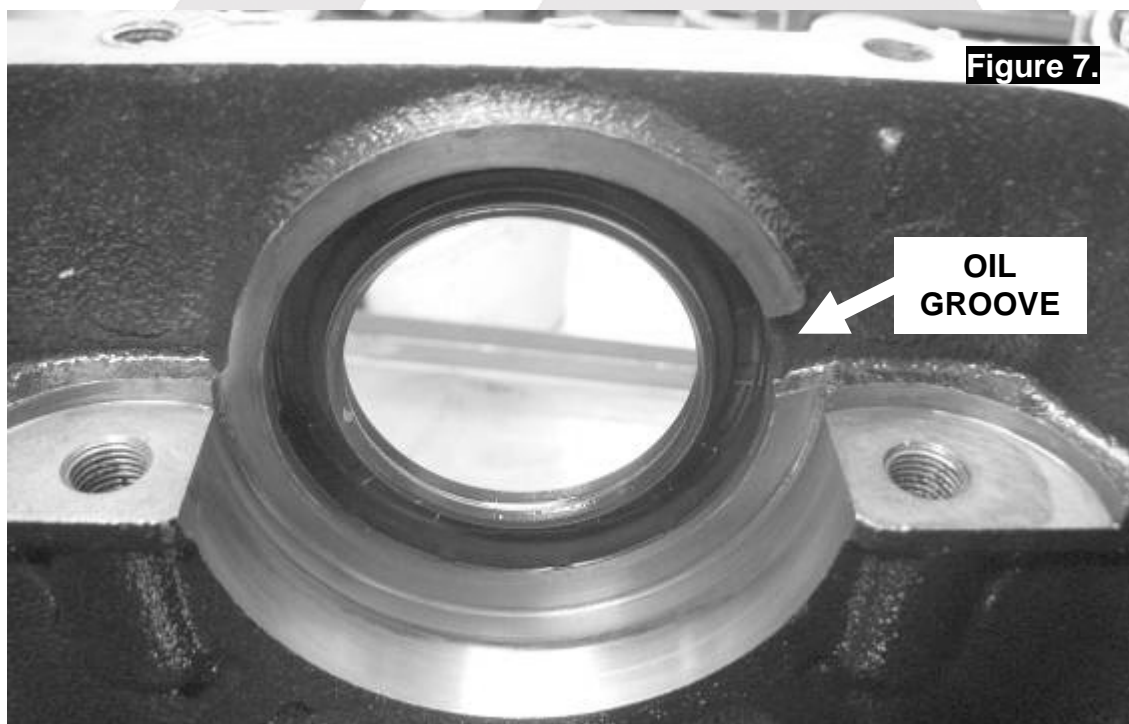

Figure 7.

OIL
GROOVE

4 Installing the Air Locker

- Consult your vehicle manufacturer's service manual to determine the carrier bearing pre-load amount specified for your vehicle.

NOTE : If your service manual specifies preload in terms of a torque value measured off the drive pinion flange, then assume a preload amount of 0.25mm [0.01"] for the following calculations. Once you have assembled the housing to check the final backlash (Refer to Section 4.7 *Final Backlash Checking*) you should verify that your preload is correct using a torque wrench and your service manual's table of values.

- Add the specified pre-load amount to the measurement taken with the feeler gauge to determine a shim amount for 'E' in Figure 6.

PRE-LOAD + END FLOAT = SHIM PACK

NOTE : Ideally, the measurement you recorded as 'E' from the *Air Locker* differential will closely match the OE Master Shim (within 0.1mm [0.004"]) and then the factory shim can be reused, however, quite often these measurements will vary slightly between one factory differential and the next.

- Use the left hand factory master shim and/or select suitable shims from the shim kit supplied with your *Air Locker* to make up a shim pack of this thickness. (Refer to section 3.2 for methods of shim adjustment).
- Cut a slot into shim pack 'E' as clearance for the seal housing tube at final assembly. Figure 8. shows the desired size of the slot.

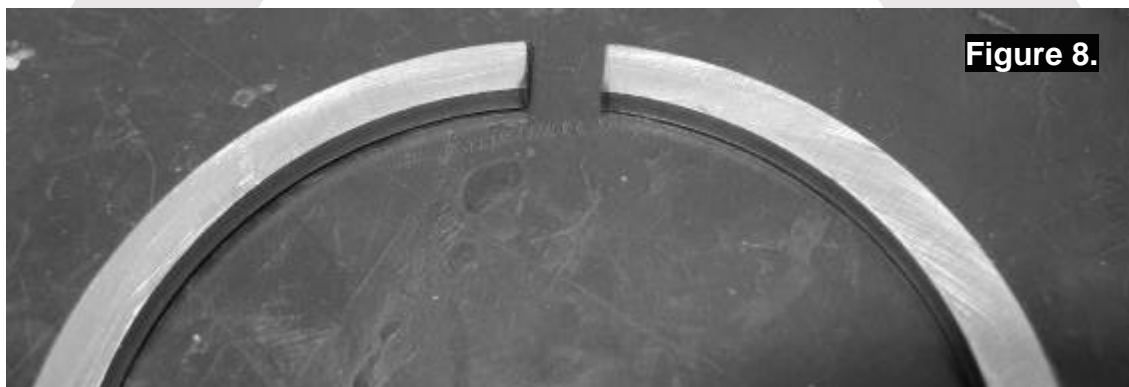

Figure 8.

- Remove any sharp or protruding edges from around the notch, and place it on the end of the seal housing, making sure that you line the slot up with the tube.

4 Installing the Air Locker

4.5 Drilling and Tapping the Bulkhead Port

An air line port must be drilled and tapped through the differential housing to mount the bulkhead fitting into.

- Mark a spot on the exterior of the differential housing toward the top in an area that will be well clear of the *Air Locker* body, the ring gear, and any other obstructions that could snag the seal housing tube. (Fig.9.)

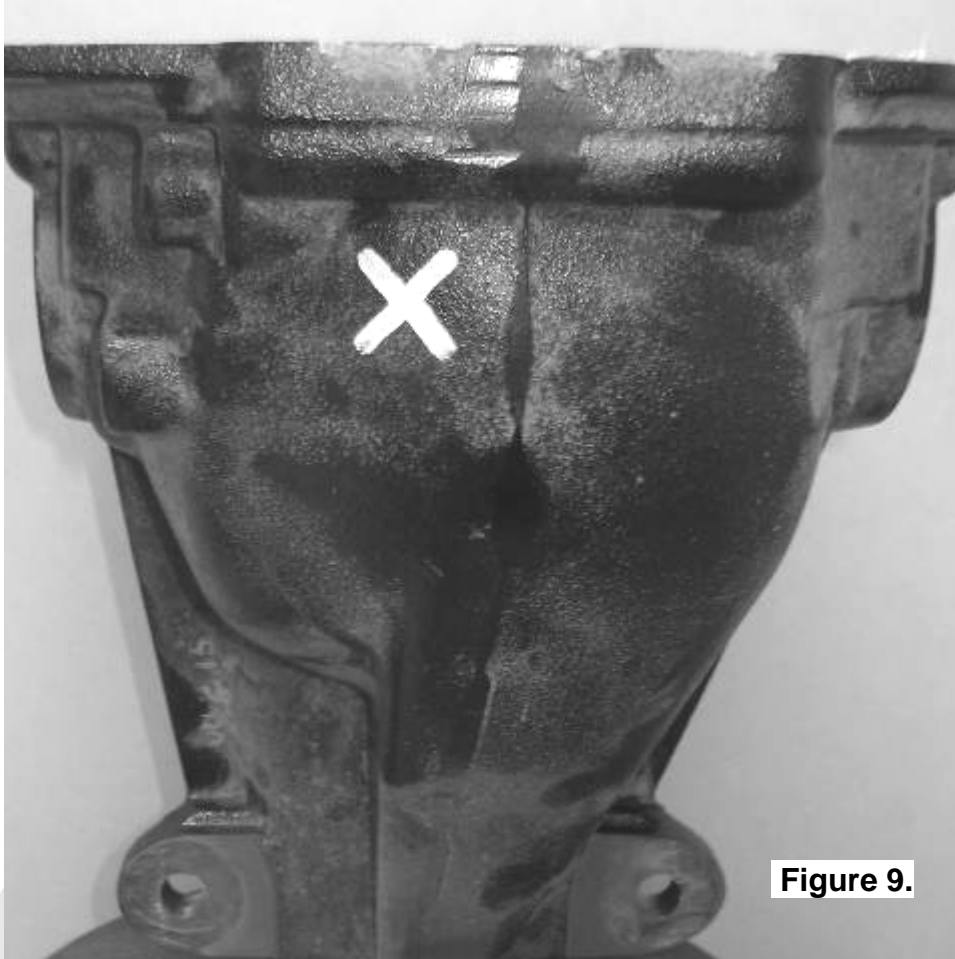

Figure 9.

- Remove the *Air Locker* from the differential housing.
- Cover the drive pinion area with a rag to protect it from metal filings.
- Secure the differential housing to the work bench.
- Drill an 11.2mm [7/16"] diameter hole through the differential housing square to the outside surface.
- Tap the hole from the outside using ¼"NPT thread tap.
- Remove any sharp edges that may chip off from around the hole and fall into the housing.
- Very carefully, remove the rags and inspect with a service light inside the housing to insure no metal filings are left behind.

4 Installing the Air Locker

4.6 Final Air Locker Assembly

- Spread the differential housing again (Refer to section 2.6).
- Hold shim packs 'D' (Refer to section 3.2) and 'E' (Refer to section 4.4) in position on the *Air Locker* ensuring to line up the seal housing tube with the slot in shim pack 'E'.
- Reinstall the *Air Locker* into the differential housing, once again ensuring to line up the seal housing tube with the oil groove (Fig. 7.).

NOTE : If the carrier is too difficult to install with the added shim pack then the spreader tension may need to be increased. Do not spread the housing more than 0.50mm [0.020"].

- Place the bearing caps in place, making sure that there is no contact between the bearing cap, master shim and seal housing tube.
- Relieve all tension on the housing spreader.
- Tighten all bearing cap bolts with a torque wrench to the torque specified in your vehicle manufacturer's service manual.

4.7 Final Backlash Checking

- Set a depth indicator on one of the ring gear teeth as in Figure 10.
- While supporting the pinion gear by holding the drive flange, rotate the differential in both directions while observing the maximum variation in depth from the indicator (i.e., the highest value minus the lowest value). This value is referred to as the ring and pinion backlash.
- Rotate the differential center 90° and measure again for accuracy.

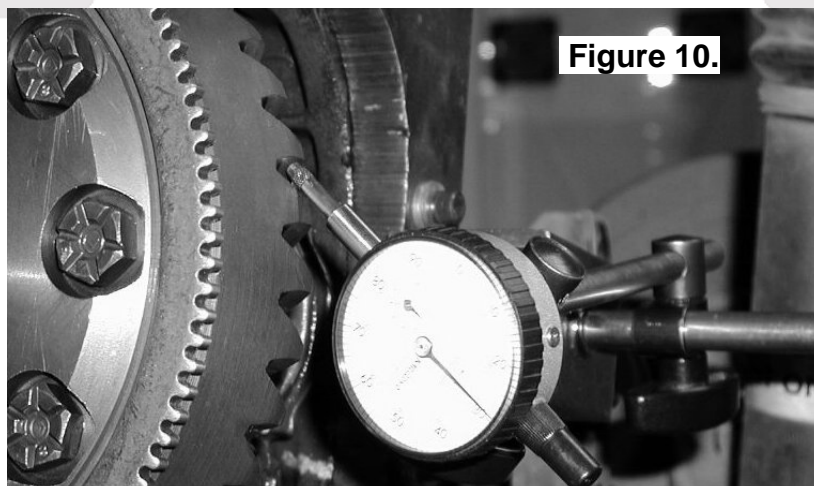

Figure 10.

4 Installing the Air Locker

- Refer to your vehicle service manual for the specified maximum and minimum amounts of backlash. If the backlash is not within the specifications then the differential will have to be removed and re-shimmed.

4.7.1 Re-Shimming the Backlash

NOTE : This step is only necessary when adjusting for incorrect backlash.

- Reapply the spreader to the differential housing.
- Remove the bearing caps.
- Remove the differential.
- To increase the amount of backlash, reduce the shim thickness 'D' (Fig.5.) and increase the shim thickness 'E' (Fig.6.) by the same amount. Reverse this step to decrease the backlash.
- Remount the differential as before.
- Release spreader tension.
- Check backlash again as before.

4.8 Profiling the Seal Housing Tube

- Without using sharp, jagged tools such as pliers (usually your hands are the best tool for this job), bend the seal housing tube so that it closely follows the profile of the differential housing and protrudes through the bulkhead port in the differential housing (refer to Fig.11., 12., & 13.).
- Trim the tube to length using automotive brake line cutters.
- Run the seal housing tube between the bearing cap, the differential housing, and the cover plate and out of the bulkhead port.
- Check that the contour of the tube will not interfere with the *Air Locker*, the ring gear, the master shim, the bearing cap, or the cover plate.

4 Installing the Air Locker

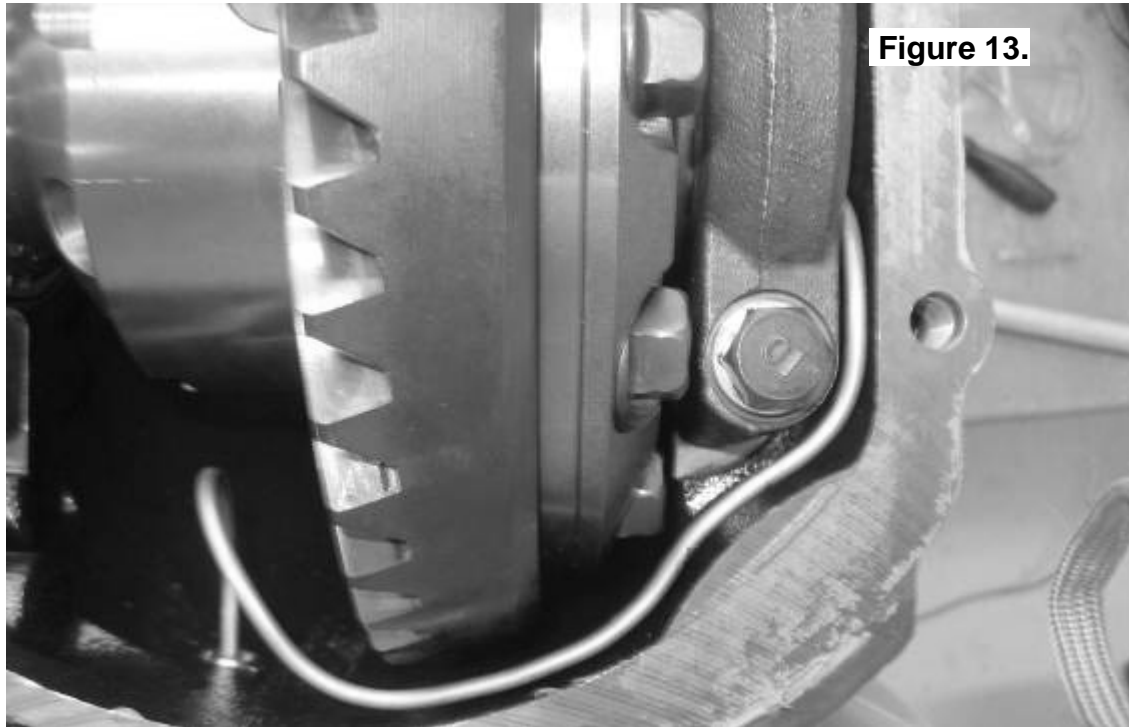

Figure 11.



Figure 12.

4 Installing the Air Locker



4.9 Setting up the Bulkhead Fitting

- Apply thread sealant to the threads of the bulkhead body.
- Screw the bulkhead body into the tapped hole, and tighten.
- Wipe the area clean of any excess thread sealant (inside and outside of the housing).
- From the outside of the housing, assemble the small O-ring over the top of the short length of seal housing tube protruding through the bulkhead fitting.
- While holding the seal housing tube into the bulkhead fitting, insert the small drilled end of the center compression nut over the extended tube as shown in the assembly diagram (Fig.14.), and screw it into the bulkhead body, and lightly tighten.

4 Installing the Air Locker

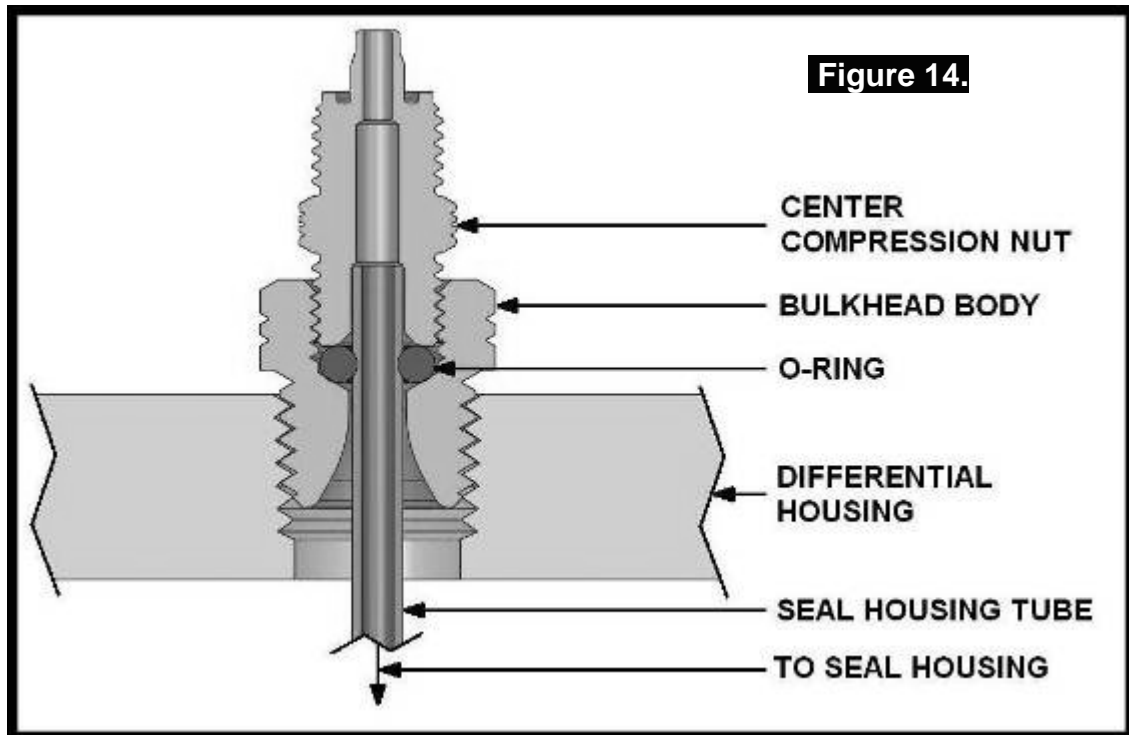

NOTE : Excessive tightening of the center compression nut is not necessary to form a good seal around the tube and may damage the O-ring, the seal housing tube, or the threads of the compression nut.

NOTE : Make sure the seal housing tube is all of the way into the center compression nut while you are tightening it.

- Again check that no part of the seal housing tube comes in contact with the moving differential components. 10mm [3/8"] should be considered adequate clearance. Gently bend the tube away from moving parts if necessary.

4 Installing the Air Locker

4.10 Bench Testing the Air Locker

- To test the *Air Locker*, when 620kPa [90 PSI] shop air is applied to the seal housing tube, the *Air Locker* should engage.
- Check all fittings and the seal housing for air leaks.
- Rotate the differential carrier by turning the pinion flange whilst applying air pressure.

NOTE : An accurate way to test for air leaks is to fit a shut-off valve to an air pressure gauge (ARB part # ALTG01). Once 620 KPA [90 PSI] is reached close the valve, disconnect the air hose, and watch to see if there is any drop in pressure. If so, this will indicate an air leak. (Fig.15.)

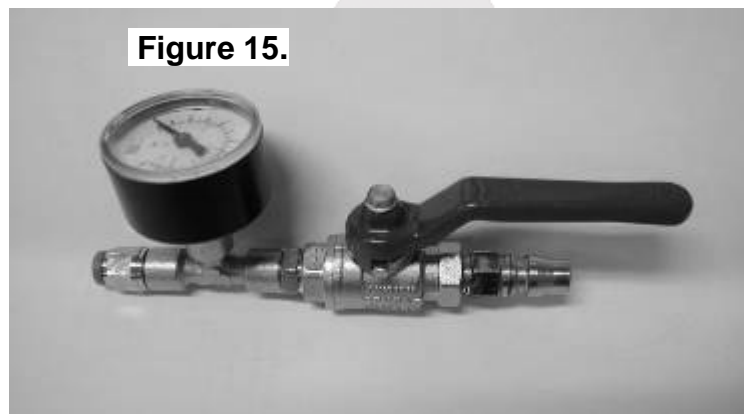

- If a leak is found to be present, spray a soap and water mixture onto the bulkhead air fitting. Bubbles should appear at any leak points.

NOTE : Do not spray this soapy mixture inside the differential.

- Check that leaky fittings have been adequately tightened.

NOTE : Do not overtighten fittings.

- Disassemble, clean threads, and reapply thread sealant if leaking persists.
- If a leak is found at the seal housing, carefully remove the seal housing assembly and examine the O-rings. Be very careful with the O-rings and check for defects, damage, wear, or presence of foreign material in the O-ring grooves. Replace if necessary.

4 Installing the Air Locker

4.11 Reinstalling the Differential and Axles

- Using an appropriate sealant or gasket, reinstall the cover plate.
- Reinstall the differential housing to the vehicle according to your vehicle service manual.
- Insert both axles fully into the housing, engaging the splines, and then gently tap them inwards.

NOTE : Be careful not to damage the axle shaft oil seals when installing the axles. Support the axle's entire weight where possible.

- Reinstall the drive shaft.



5 Installing the Air System

5.1 Mounting the Solenoid

5.1.1 Connection to an ARB Air Compressor (Fig.16.)

- Remove one of the 1/8" BSP plugs from its port in the compressor tank.
- Apply Teflon paste to the nipple (1/8" X 1/8" BSP) and insert it into the port and tighten.
- Apply Teflon paste to the free end of the nipple.
- Assemble the inlet port side of the solenoid (stamped with a '1') onto the nipple and tighten. The solenoid should be rotated into a position that does not obstruct any other ports on the compressor tank.

NOTE : The solenoid exhausts compressed air through the center of the black retaining cap when the *Air Locker* is disengaged. Make sure this orifice cannot be obstructed.

- Apply Teflon paste to the threads of the 5mm push-in fitting and assemble it into the solenoid outlet port (stamped "2") and tighten.

ARB

Air Compressor

Figure 16.

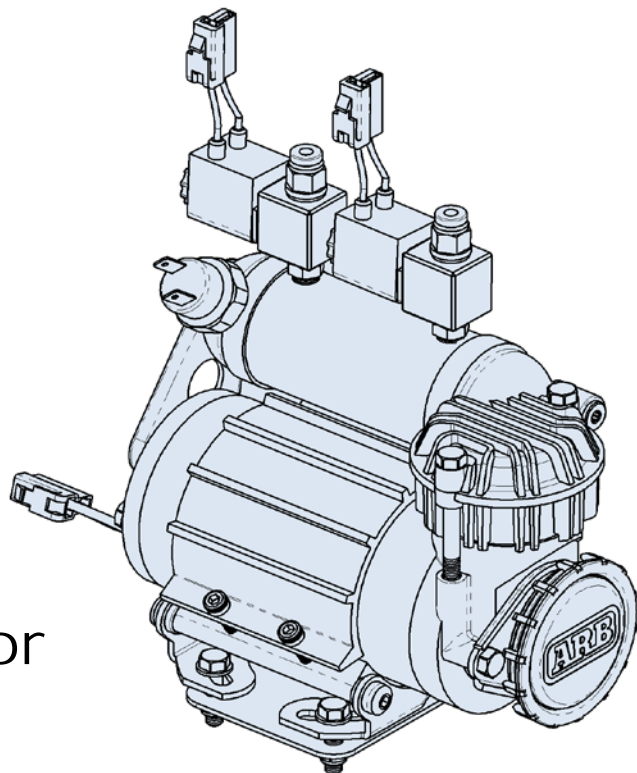

5 Installing the Air System

5.1.2 Connection to an Alternate Air Source

For ease of installation, quality of air supply, and a high level of dependability from your *Air Locker(s)*, ARB strongly recommends use of a genuine ARB Air Compressor, however, the *Air Locker* air system can be operated on any alternate air source that meets each of the following guidelines:

- Must supply a minimum of 85PSI [586kPa].
- The Air source should have a tank capacity that enables it to actuate the *Air Locker(s)* in one charge so that no hesitation is experienced when locking one or two differentials.

HINT : A good way to insure that you have the necessary capacity is to make sure you can engage, disengage, and then reengage your *Air Locker(s)* without the air source having to regenerate (e.g., without the compressor turning on to refill the tank).

- Must supply clean air, free of rust, dirt, water, or other foreign matter.
- Must match the 1/8" BSP porting of the *Air Locker* solenoid.
- Mount solenoid within close proximity of the air supply and secure it from the effects of vibration and shock.
- Connect the air supply to the 1/8" BSP inlet port of the solenoid (stamped "1" on the solenoid body) using thread sealant.

IMPORTANT :

ARB cannot warrant your *Air Locker(s)* against damage caused as a result of using an alternate air supply. If you have any doubts as to the suitability of your air system to use in an *Air Locker* system, consult your ARB distributor.

5 Installing the Air System

5.2 Running and Securing the Air Line

The path taken by the air line from your air source (i.e., compressor) to your *Air Locker* is unique to your vehicle and the position of your air source. Plan ahead carefully when running the air line and always follow these guidelines:

- Account for axle travel when running the line from the axle to a fixed point on the vehicle. Leave enough slack in the air line to allow for maximum suspension travel in both directions.
- Avoid leaving large lengths of air line hanging underneath the vehicle where they may get tangled on rocks, sticks, etc.

HINT : **Cable tying the air line to one of your flexible brake lines will account for axle travel and should help keep your line from getting snagged.**

- Run the air line all the way from the compressor to the differential before trimming either end of the line to length. This will save complications that may arise if the air line has to be removed.
- Make sure the line does not contact sharp edges or abrasive surfaces that may damage the air line over time.
- Do not run the air line around tight bends which may kink the air line and restrict or block the air flow.
- Keep the air line well away from your vehicle's exhaust components. Air lines will melt if subjected to extreme heat.
- Do not run more air line than necessary. Excess line volume created when coiling the left over hose, using unusually large diameter hose, etc., will increase drain on the compressor tank resulting in the compressor running more often than needed.
- Support the air line by tying it back with cable ties wherever possible.
- At the solenoid end of the air line, trim the line to length with a sharp knife.

NOTE : **To remove the air line from the push-in fitting; while holding the flange of the fitting out, push the air line into the fitting as far as possible, then press the flange inward, then pull the air line free of the fitting.**

- To attach the air line to the push-in fitting of the solenoid; insert the line firmly into the fitting, pull outward on the flange of the fitting while holding the line as far into the fitting as possible, and then gently pull outward on the air line to clamp the line in place.

5 Installing the Air System

5.3 Connection to the Bulkhead Fitting

- Trim the air line to length using a sharp knife.
- Insert the support spring over the end of the air line - small end first. (Fig.17.)
- Insert the outer compression nut over the air line.
- Push the airline onto the barb on the center compression nut, ensuring that it is pushed all the way to the end.



HINT : If the tube is too difficult to push on, place the end of the air line into a cup of boiled water to soften the tubing.

- Screw on the outer compression nut and tighten, while supporting the center compression nut with a 3/8" spanner. The airline is now attached to the center compression nut.

NOTE : The outer compression nut will tighten against a stop. Over tightening will not create a better seal.

- Assemble the support spring over the outside of the outer compression nut.
- Secure any loose sections of tube with a cable tie.

6 Mounting & Connecting the Electrical System

6.1 Mounting the Actuator Switch(es)

Air Locker actuator switch(es) can be easily panel mounted inside the vehicle in a 21mm x 36.5mm [0.83" x 1.44"] rectangular cutout.

NOTE : Only attach the cover plate to the face of the switch once the switch has been mounted and wired correctly as the cover plates are designed to be difficult to remove.

For reasons of safety and for ease of operation, the *Air Locker* actuator switch(es) should be mounted in a location picked to best suit the operator. Make sure you have taken the following points into consideration:

- Switch(es) MUST be mounted and should never be allowed to simply dangle from the wiring loom during vehicle use.
- Switch(es) should be within easy reach of the driver. Ideally, any *Air Locker* switch should be able to be operated without physical effort or distraction to the driver.
- Switch(es) should be mounted within the line of sight of the driver so that switch position ('ON' or 'OFF') can be visually determined by the rocker position and the illumination state.
- The position of the switch(es) should best eliminate any possibility of accidental operation by the driver or one of the passengers.
- Switch cutout position(s) must be located in an area with a minimum of 50mm [2"] of clearance behind the face of the cutout.
- Switch(es) should not be mounted where they will be exposed to water (e.g., in the lower section of an inner door panel).
- ARB recommends that you apply the *Air Locker* Warning Sticker (ARB part # 210101) within close visual proximity of the switch location.

NOTE : If no adequate position can be found on existing dashboard panels, a surface mounted bracket (Fig.18.) may be purchased from your ARB *Air Locker* distributor to suit 1, 2, or 3 switches.



Figure 18.

6 Mounting & Connecting the Electrical System

6.2 Wiring the Actuator System

6.2.1 Connection to an ARB AIR COMPRESSOR

When wiring the *Air Locker* actuator switch(es) and solenoid(s) to an ARB Air Compressor, all connections can easily be set up directly from the supplied wiring loom. (Fig. 19.)

NOTE : 180409 model loom shown for reference only. Refer to your ARB Air Compressor Installation Guide for details on configuring your installation.

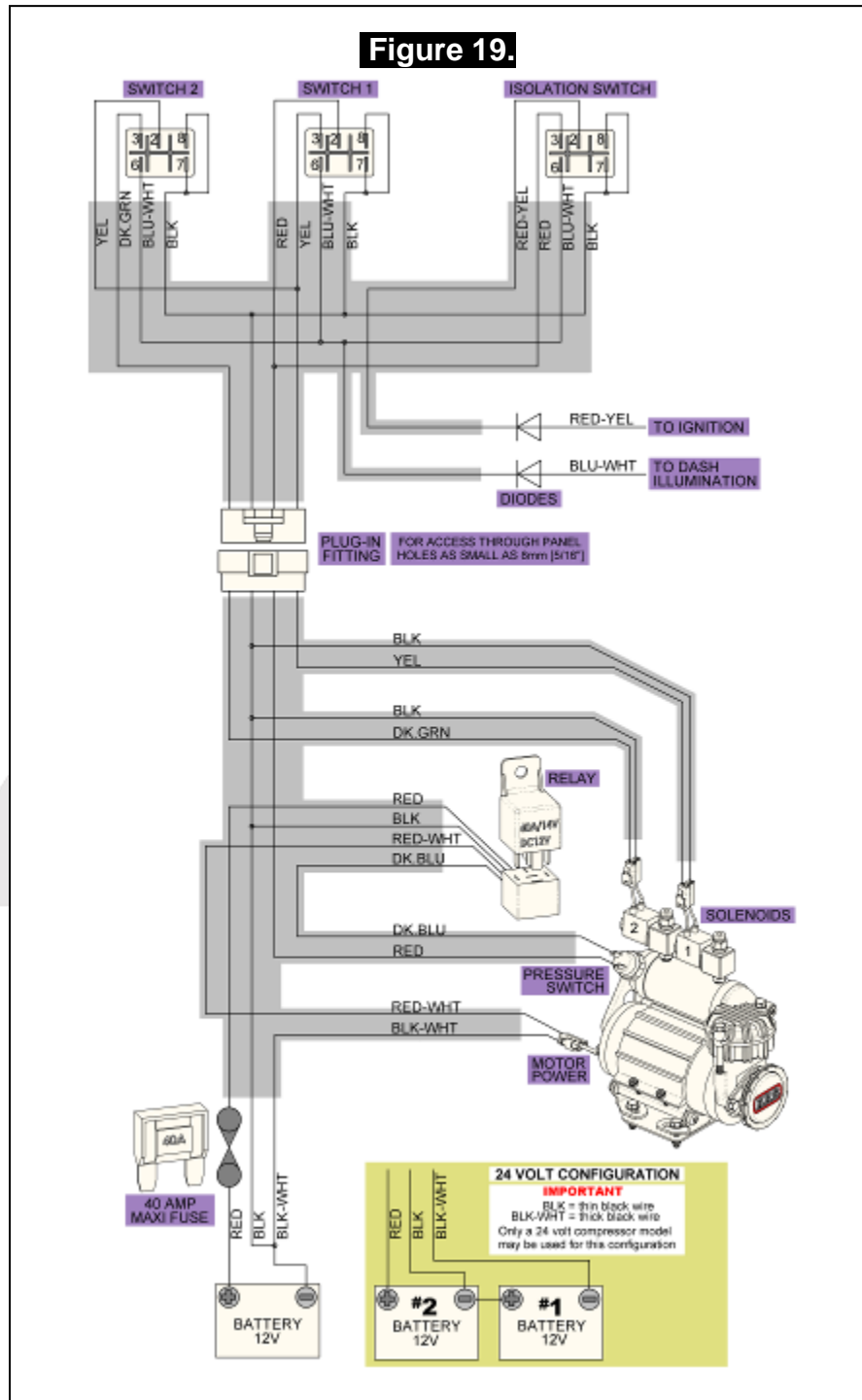

6 Mounting & Connecting the Electrical System

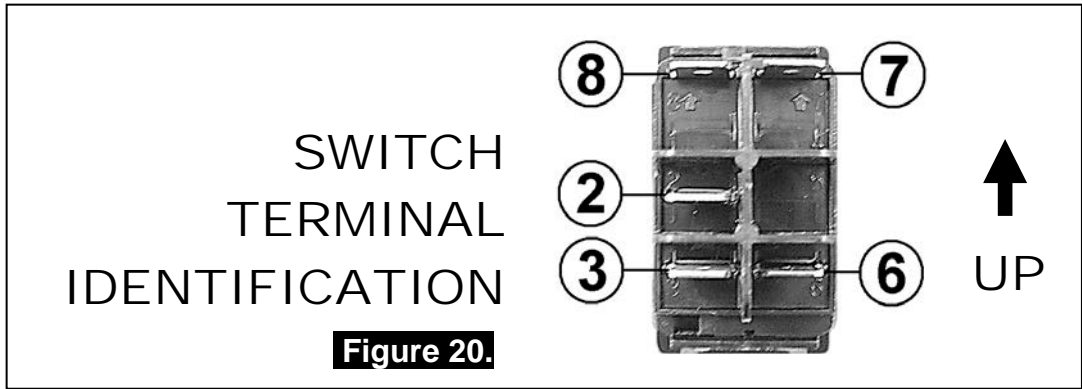

6.2.2 Connection to an Alternate Air Source

When connecting the actuation switch to an alternate air source, the switch(es) should be wired according to Figures 21. and 22., depending on whether one or two *Air Lockers* will be installed in the vehicle.

6.2.2.1 Single Air Locker System

- If only one *Air Locker* is to be installed in the system, the switch and solenoid should be wired according to Figure 21. regardless of whether the *Air Locker* has been installed in the front or rear axle of the vehicle.
- Attach the appropriate switch cover (i.e., 'FRONT' or 'REAR') to the switch.

NOTE : Refer to Figure 20. for the correct switch terminal identification and switch orientation.

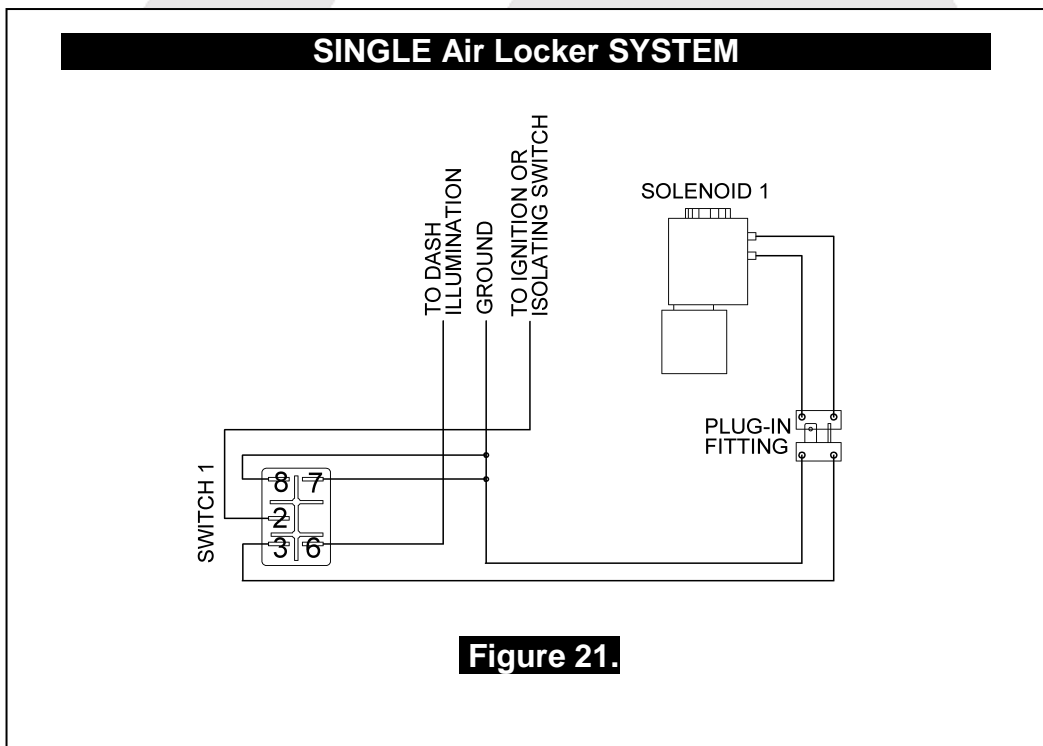

6 Mounting & Connecting the Electrical System

6.2.2.2 Dual Air Locker System

- If two *Air Lockers* are to be installed in the system, ARB recommends that the switches and solenoids be wired according to Figure 22. For safety reasons, this configuration allows SOLENOID 2 to be actuated only if SOLENOID 1 is already on.
- Attach the “REAR AIR LOCKER” switch cover to SWITCH 1, and the “FRONT AIR LOCKER” switch cover to SWITCH 2.

NOTE : Refer to Figure 20. for the correct switch terminal identification and switch orientation.

- Configure SOLENOID 1 as the air line leading to the rear axle *Air Locker*, and SOLENOID 2 as the air line leading to the front axle *Air Locker*.

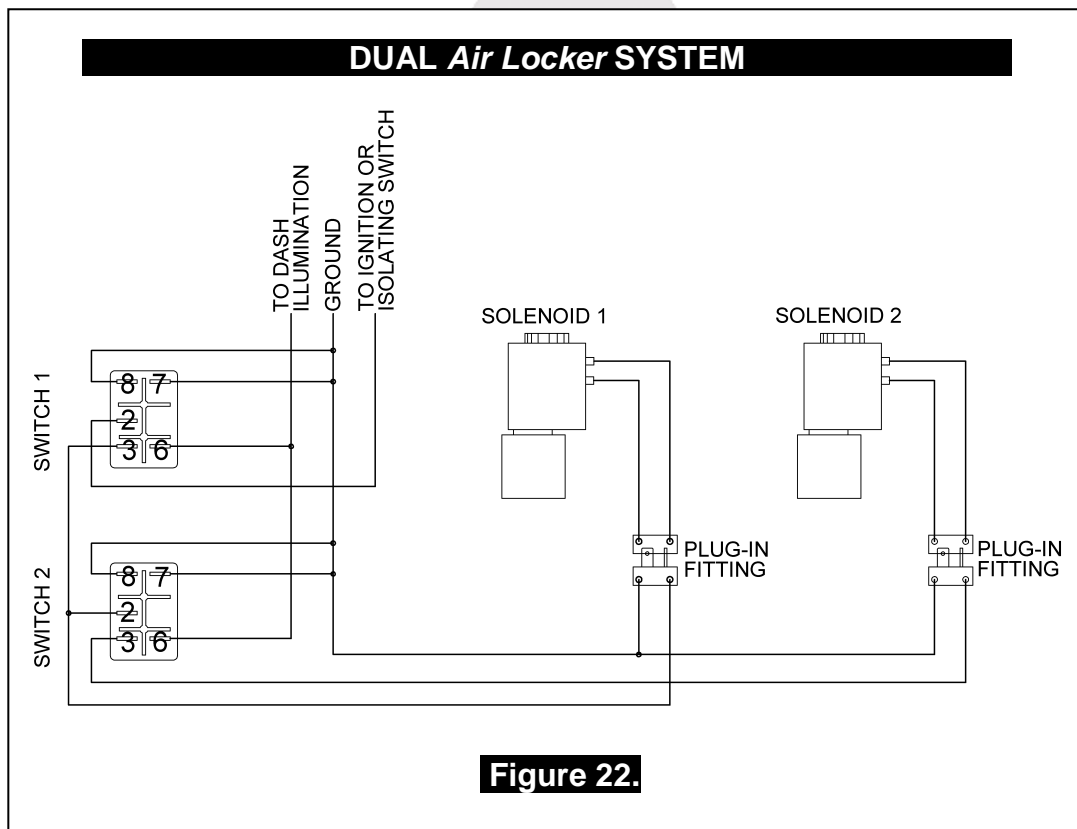

7 Testing & Final Assembly

7.1 Leak Testing

- With the vehicle parked and the engine off, turn the compressor on and wait until the air system is fully charged.

NOTE : With the *Air Locker(s)* disengaged, the air source (i.e., compressor) should not have to recharge over time. Intermittent recharging without *Air Locker* use usually indicates a leak at the solenoid fittings or at the compressor tank O-ring seal.

- Actuate the *Air Locker(s)*.
- The compressor should not come on again for a period of at least 15min. Air system recharging within that time period would indicate that a leak is present in the system.

NOTE : If an alternate air source (e.g., an air cylinder or a belt driven air pump) is used instead of a compressor, the air system will have to be leak tested with a pressure gauge and a shut-off valve in series before the solenoid input.

- If a leak is found to be present, spray a soap and water mixture onto all air fittings in the system while the compressor is fully charged. Bubbles should appear at any leak points.
- Check that leaky fittings have been adequately tightened.
- Disassemble, clean threads, and reapply thread sealant if leaking persists.

7.2 Testing the Air Locker Actuation

To test that your air system, electrical system, and your *Air Locker* differential is functioning correctly:

- Support the vehicle such that the wheels are free to rotate (e.g., on axle stands, a chassis hoist, etc.)
- Leave the parking brake off, the transmission in neutral, and the *Air Locker* switch 'OFF'.
- Turn the ignition to the 'ON' position (leaving the motor off). The large illuminating symbol on the *Air Locker* switch cover should be 'OFF'.
- Turn the compressor (or alternate air source) on to charge the air supply up to its maximum pressure.

7 Testing & Final Assembly

- Rotate one wheel by hand.
- The wheel should rotate freely and the opposite wheel should be turning in the opposite direction without any resistance or mechanical noise from within the differential.
- Turn the *Air Locker* switch to the 'ON' position. The illuminated symbol on the switch cover should light up.
- Rotate the same wheel again.
- Both wheels should rotate together.
- Turn the switch off again.
- Rotate the same wheel.
- The wheels should again rotate in opposite directions.

7.3 Filling the Differential

NOTE : Consult the *ARB Air Locker Operating & Service Manual* for recommendations on differential lubricant specifications.

- Remove the filler plug.
- Refill the differential until level with the filler hole.
- Rotate the differential center 2 full turns.
- Check the oil level and add oil if necessary.
- Replace filler plug (apply thread sealant to filler plug before inserting if it is a threaded type plug).
- Wipe differential housing clean of any oil or grease which may collect dirt or other abrasive particles.

7 Testing & Final Assembly

7.4 Post-Installation Check List

Now that the *Air Locker* installation has been completed, ARB recommends that you take the time to complete the following check list just to insure that you haven't missed any of the vital steps.

- The air system has been leak tested.
- Thread locking compound was used on the ring gear bolts.
- All torque settings comply with the vehicle manufacturer's specs and were set with an accurate torque wrench.
- Differential fluid complies with ARB recommendations and has been filled to the correct level.
- All air lines and wiring have been securely cable tied to resist snagging.
- Switch(es) have been securely mounted within operator reach, yet well away from danger of accidental engagement.
- Switch(es) function properly and illuminate to indicate that *Air Locker(s)* are engaged.
- All operators who are to use the *Air Locker* have read, and fully understand the *ARB Air Locker Operating & Service Manual*.
- The *Air Locker* Warning Sticker has been located within close proximity of the actuator switch(es).

INSTALLATION PERFORMED BY: _____

DATE OF INSTALLATION: _____

ODOMETER READING: _____

ARB AIR LOCKER SERIAL No: _____



8 Parts List

8.1 Exploded Assembly Diagram (See itemized parts list overleaf)

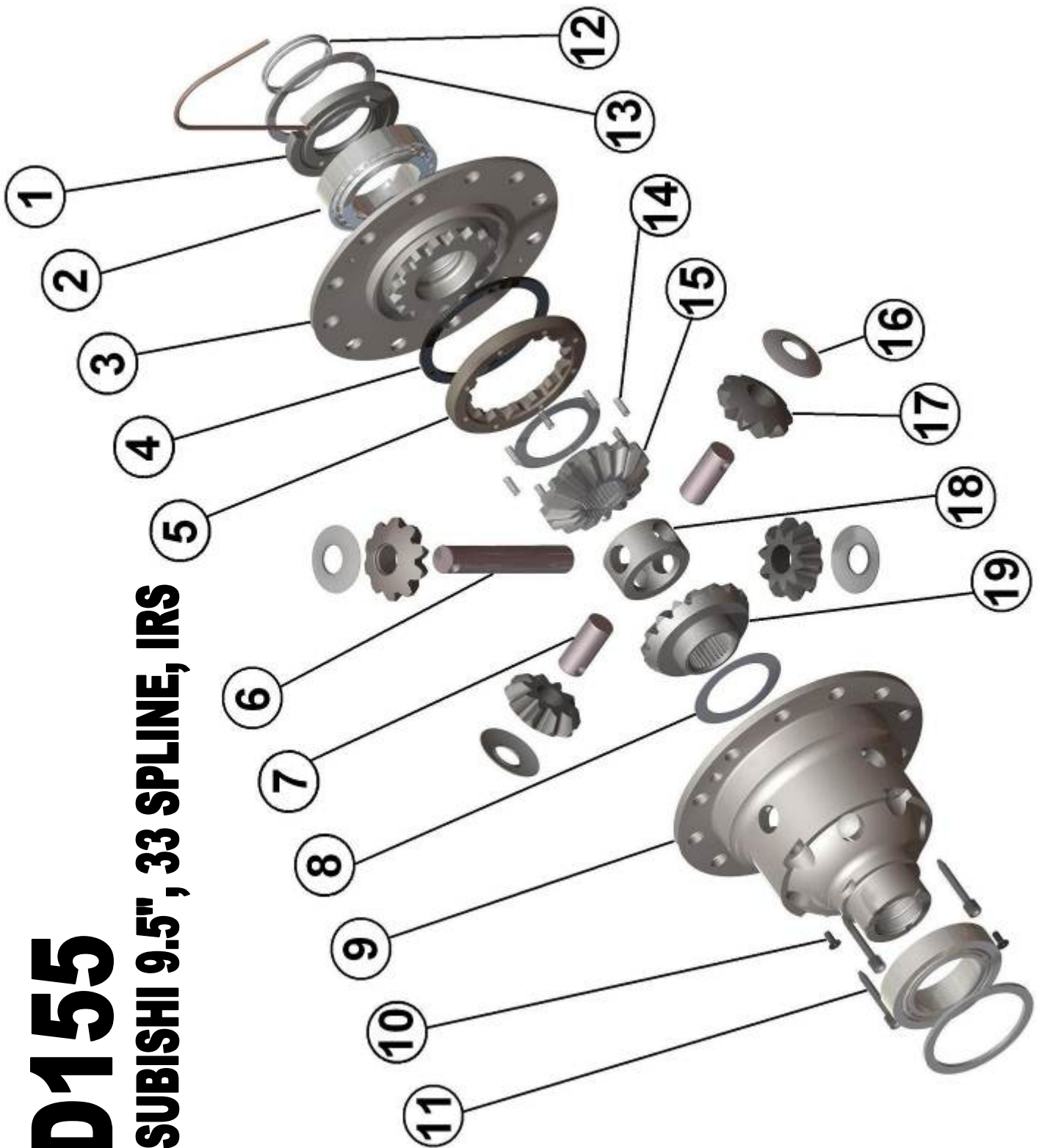

RD155

MITSUBISHI 9.5", 33 SPLINE, IRS

Figure 23.

8 Parts List

8.2 Itemized Parts List

(See exploded diagram Figure 23.)

AIR LOCKER MODEL No. :		RD155	
ITEM #	QTY	DESCRIPTION	PART #
01	1	SEAL HOUSING ASSEMBLY	081813
02	2	TAPERED ROLLER BEARING	NOT SUPPLIED
03	1	FLANGE CAP ASSEMBLY	027324
04	1	BONDED SEAL	160702
05	1	CLUTCH GEAR	050806
06	1	LONG CROSS SHAFT	060204
07	2	SHORT CROSS SHAFT	060403
08	2	SIDE GEAR THRUST WASHER	151010
09	1	DIFFERENTIAL CASE	013024
10	2	COUNTERSUNK SCREWS	200213
11	3	CROSS SHAFT RETAINING PIN	120601
12	2	SEAL HOUSING O-RING	160207
13	1	SHIM KIT	SHK005
14	12	RETURN SPRING	150113
15	1	SPLINED SIDE GEAR	728H221**
16	4	PINION THRUST WASHER	151110
17	4	PINION GEAR	728H221**
18	1	SPIDER BLOCK	070201
19	1	SIDE GEAR	728H221**
*	1	BULKHEAD FITTING KIT (O-RING TYPE)	170111
*	1	PUSH-IN FITTING (5mm to 1/8" BSPP)	170201
*	1	AIR LINE (5mm DIA X 6m LONG)	170301
*	1	NIPPLE, (1/8" to 1/8" BSPT)	170501
*	1	SOLENOID VALVE (12V)	180103
*	1	SWITCH	180209
*	1	SWITCH COVER (REAR)	180211
*	10	CABLE TIE	180301
*	1	WARNING LABEL	210101
*	1	BUMPER STICKER	210102
*	1	OPERATING & SERVICE MANUAL	210200
*	1	INSTALLATION GUIDE	2102155

* Not illustrated in exploded view.

** Available only as complete 6 gear set

Part No. 2102155

Revision 7/10/2013

Copyright © 2013 by ARB Corporation Limited

